

EMF69E

60cm Stainless Steel 9 Function Electric Oven



FULLY FEATURED FOR GREAT COOKING

With a choice of different cooking functions including Air Fry this oven has enough options to satisfy the most demanding home chef.

ELECTRONIC PROGRAMMER

A digital clock that also can be used to set the time for the oven to switch on and switch off. Designed to be easy to program without referring to the manual each time.

AIR FRYER FEATURE

Includes an Air Fryer basket and Air Fryer function selection. Cooks anything that normally requires turning such as chips, chicken wings, sausages or crumbed fish fillets. Excellent for dehydrating foods.

TRIPLE GLASS DOOR

Triple Glass ventilated door keeps surface temperatures down. Much more comfortable and safer for the user. The large window provides a clear view of the cooking process.

TECHNICAL FEATURES

MAIN FEATURES	
Gross Volume	67 Litres
Usable volume	57 Litres
Side Racks	5 Shelf Levels
Control	Knob Controls
Cooling Fan	Automatic
Timer	Electronic programmer
Maximum Temperature	260 C
Total Max Power Consumption	3440W
Electrical Connection	15amp plug in connection
Removable door	For cleaning
Oven Internal Finish	Black porcelain enamel
Power cord length	1.2 metre
DESIGN FEATURES	
Colour	Black Glass, Stainless Steel
Oven Light	Halogen
Inner Door	Full Glass - Removable
Handle	Anodized aluminium
Door Construction	Triple Glass Ventiladed
Control knobs	Anodized aluminium
INCLUDED ACCESSORIES	
Side Racks	2 - snap out for cleaning
Wire Shelves	2 - with 5 positions
Air Fryer basket	1 - option up to get more
Grill Tray	1 - porcelain enamel
Insert Rack for Grill Tray	1 - holds food off grill tray
Installation kit	Screws and fittings
Instruction Manual	Includes installation guide

OVEN CAVITY	
Rear fan	Fan forced function
Side Chromed Racks	Removable
Cooking Elements	Grill, top & bottom and rear circular element,
Internal Oven Dimensions mm	470W x 340H x 420D
OVEN DOOR	
Full glass inner door	Easily removed
Triple glass door	Insulates oven
Removable inner glass	Allows cleaning
OVEN COOKING FUNCTIONS	
Cooling fan - Automatic	Surfaces stay cool
Thermostat control	Accurate temp control
1. Light	Lights the cavity
2. Air Fry	Fast moving heat
3. Classic bake	Even still heat
4. Fan Forced	Rapid, efficient heat
5. Grill	Heat from the top
6. Double Grill	Heat from 2 elements
7. Double Fan Grill	Air moved from top
8. Pastry	Heats from the bottom
9. Fan assisted	Even fanned heat
DIMENSIONS & WEIGHTS	
Unpacked Weight	35Kg
Packed Weight	40Kg
Packed Dimensions	660W x 650H x 650D
Unpacked Dimensions	595W x 595H x 570D
WARRANTY	
3 Years Parts and Labour	In home service
BAR CODE	
0793618352486	

EMF69E

60cm Stainless Steel 9 Function Electric Oven

INSTALLATION NOTES

Overall dimensions

This model oven uses the conventional dimensions of the majority of 60cm built in ovens making it an ideal oven to use for replacement purposes. In most cases the oven will fit into existing cupboard spaces without need for modification to the kitchen.

Electrical Connection

The oven has a 1.2M cord. This oven is fitted with a 15amp plug. The oven should be installed with a unique circuit with the appropriate amps, not sharing the connection with other appliances. It is an important requirement.

3 Year Warranty

A full nationwide 3 Year Warranty applies.

Proof of purchase and proof of correct installation by a licensed installer is required for warranty service.

Call Glem Gas Australasia on 1 300 307 917 for details or send an email to info@glemgas.com.au and we will respond promptly.

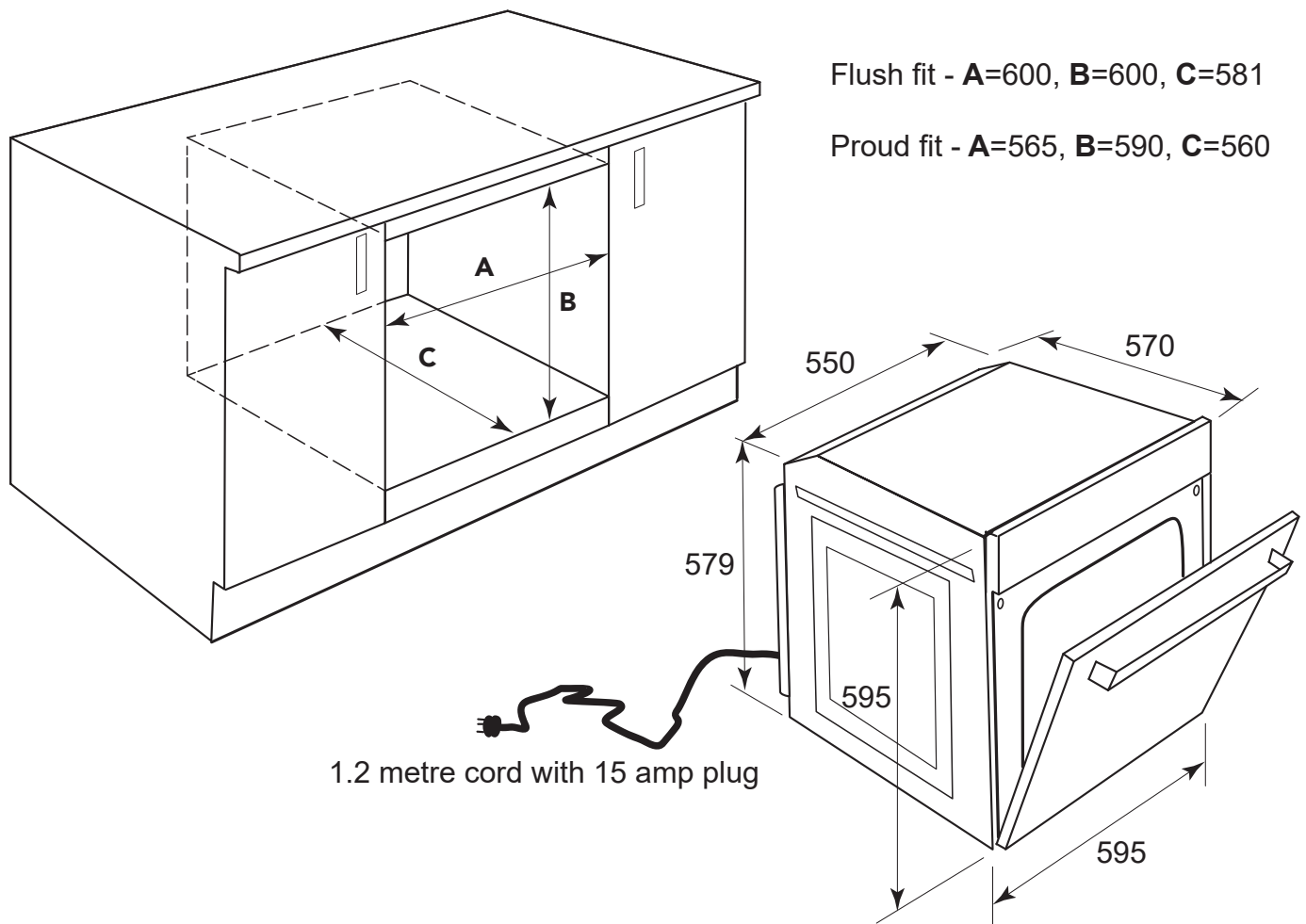

Please note:

Every effort has been made to ensure this information is correct. However, due to product improvement Glem reserves the right to make changes to products without prior notice.