

# Hush

## Low Noise Rangehoods

*Maximum Extraction - Minimum Noise*

### EMHUSH60C 60cm Slim Line Canopy

#### Functions and features

1200 cubic metres per hour extraction

Ceiling cavity motor for silent operation

Low consumption LED lights x 4

Outlet diameter 150 mm

3 Speed fan

2 dishwasher safe stainless steel filters

2 mesh filters included as an option

2 year warranty

Ready to go. Easy to install.

OFF BOARD MOTOR TECHNOLOGY  
Ultra Quiet - with no noise in the kitchen  
Powerful 1200 cubic metres/hour extraction  
Long Life stainless steel baffle filters  
Low consumption - Hi efficiency LED lighting

**24/7**  
MONTH WARRANTY YEAR MOTOR WARRANTY

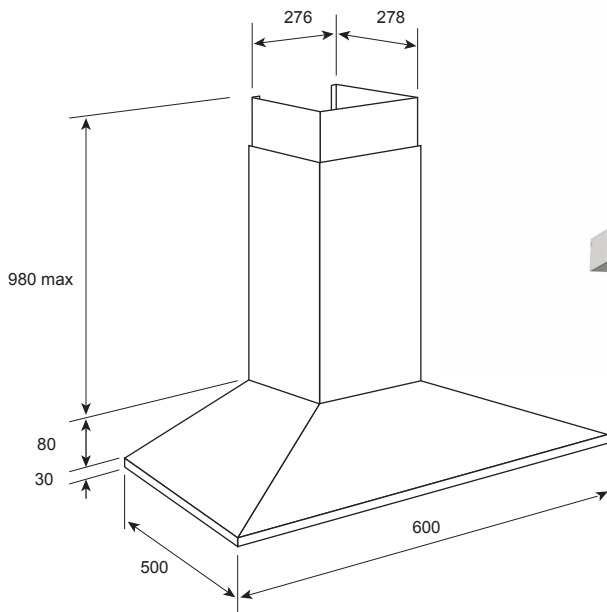

Please note:

Every effort has been made to ensure this information is correct. However, due to constant product improvement we reserve the right to make changes to products without prior notice.  
[www.emiliappliances.com.au](http://www.emiliappliances.com.au)

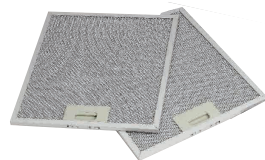
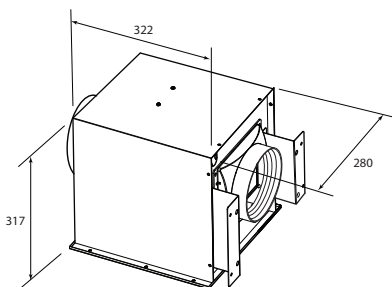

Mesh filter option included



Full installation kit included.  
Duct tape and external vent not supplied.